

Milling arbors for screw-in cutters

Porte-fraises pour fraises à queue filetée



Verwendung:
Zur Aufnahme von Einschraubfräser mit Gewinde.

Application:
For mounting screw-in cutters with thread.

Application:
Pour le serrage de fraises à queue filetée.

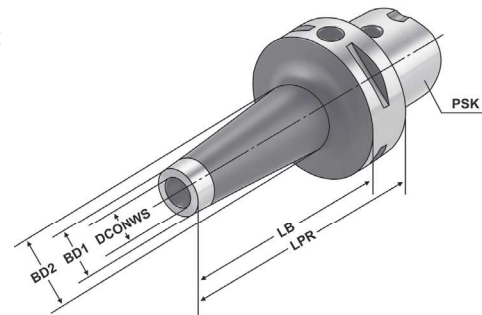

Bestell-Nr. Order no. Référence	PSK	THSZWS	DCONWS	BD1	BD2	LPR	LB
C6.06.08	C6	M8	8,5	13	23	105	75
C6.06.10	C6	M10	10,5	18	25	105	75
C6.06.12	C6	M12	12,5	21	31	105	75
C6.06.16	C6	M16	17	29	34	105	75

Empfohlenes Anzugsmoment
Recommended tightening torques
Torques de serrage recommandés

M6	10 Nm
M8	25 Nm
M10	40 Nm
M12	60 Nm
M16	50 Nm

